



### »» Features

- 20A miniature PCB Power Relay.
- 1 form A contact configuration with quick terminal type.
- 5KV dielectric strength, 10K surge voltage between coils to contact.
- Ideal for high rating Home Appliances of heating element control.
- Comply with RoHS-Directive 2002/95/EC.
- Relay with AgCdO contact material do not comply with the Directives.

### »» Type List

#### ◆ Standard Type

Terminal style	Contact form	UL Insulation system approval	Designation (provided with)
			Flux tight
P (PCB terminal)	1A (SPNO)	-----	302P-1AB-C
		-----	302P-1AH-C
		-----	302P-1AC-C
		F	302P-1AB-F-C
		F	302P-1AH-F-C
		F	302P-1AC-F-C
WP (PCB terminal & Quick terminal)	1A (SPNO)	-----	302WP-1AB-C
		-----	302WP-1AH-C
		-----	302WP-1AC-C
		F	302WP-1AB-F-C
		F	302WP-1AH-F-C
		F	302WP-1AC-F-C
WP1 PCB terminals (2 coil terminals & 1 NO terminal) & Quick terminals	1A (SPNO)	-----	302WP1-1AB-C
		-----	302WP1-1AH-C
		-----	302WP1-1AC-C
		F	302WP1-1AB-F-C
		F	302WP1-1AH-F-C
		F	302WP1-1AC-F-C
WP2 PCB terminals (2 coil terminals & 2 stationary support terminals) & Quick terminals	1A (SPNO)	-----	302WP2-1AB-C
		-----	302WP2-1AH-C
		-----	302WP2-1AC-C
		F	302WP2-1AB-F-C
		F	302WP2-1AH-F-C
		F	302WP2-1AC-F-C

## ◆ High Sensitivity Type

P (PCB terminal)	1A (SPNO)	-----	302NP-1AB-C
		-----	302NP-1AH-C
		-----	302NP-1AC-C
		F	302NP-1AB-F-C
		F	302NP-1AH-F-C
		F	302NP-1AC-F-C
WP (PCB terminal & Quick terminal )	1A (SPNO)	-----	302NWP-1AB-C
		-----	302NWP-1AH-C
		-----	302NWP-1AC-C
		F	302NWP-1AB-F-C
		F	302NWP-1AH-F-C
		F	302NWP-1AC-F-C
WP1 PCB terminals (2 coil terminals & 1 NO terminal) & Quick terminals	1A (SPNO)	-----	302NWP1-1AB-C
		-----	302NWP1-1AH-C
		-----	302NWP1-1AC-C
		F	302NWP1-1AB-F-C
		F	302NWP1-1AH-F-C
		F	302NWP1-1AC-F-C
WP2 PCB terminals (2 coil terminals & 2 stationary support terminals) & Quick terminals	1A (SPNO)	-----	302NWP2-1AB-C
		-----	302NWP2-1AH-C
		-----	302NWP2-1AC-C
		F	302NWP2-1AB-F-C
		F	302NWP2-1AH-F-C
		F	302NWP2-1AC-F-C

## »» Ordering Information

302 □ WP - 1A H - □ - C  
 1 2 3 4 5 6 7

- |          |  |          |                                |
|----------|--|----------|--------------------------------|
| 1. 302   | -- Basic series designation  | 4. 1A    | -- Single pole normally open   |
| 2. Blank | -- Standard type   | 5. B     | -- Contact material AgCdO      |
| N        | -- High sensitivity type   | BA       | -- Contact material AgCdO + Au |
| 3. P     | -- PCB terminals   | C        | -- Contact material AgNi       |
| WP       | -- PCB terminals and Quick terminals   | CA       | -- Contact material AgNi + Au  |
| WP1      | -- PCB terminals (2 coil terminals and 1 NO terminal) and Quick terminals                  | H        | -- Contact material AgSnO      |
| WP2      | -- PCB terminals (2 coil terminals and 2 stationary support terminals) and Quick terminals | HA       | -- Contact material AgSnO + Au |
|          |  | 6. Blank | -- Standard type               |
|          |  | F        | -- Class F                     |
|          |  | 7. C     | -- Flux tight                  |



### »» Contact Rating

Resistive load	17A 240VAC
----------------	------------

### »» Coil Rating (DC)

#### ◆ Standard Type

Rated voltage (V)	Rated current $\pm 10\%$ at 23°C (mA)	Coil resistance $\pm 10\%$ at 23°C ( $\Omega$ )	Max. continuous voltage at 85°C	Pick up voltage(Max) at 23°C	Drop out voltage(Min) at 23°C	Power consumption at rated voltage
3	176	17	160 % of rated voltage	75 % of rated voltage	10 % of rated voltage	approx. 0.53W
5	106	47				
6	88	68				
9	59	153				
12	44	272				
15	35	425				
18	29	611				
21	25	832				
24	22	1,087				
36	15	2,445				
48	11	4,347				
60	8.8	6,792				
100	5.3	18,868				
110	4.8	22,830				

#### ◆ High Sensitivity Type

Rated voltage (V)	Rated current $\pm 10\%$ at 23°C (mA)	Coil resistance $\pm 10\%$ at 23°C ( $\Omega$ )	Max. continuous voltage at 85°C	Pick up voltage(Max) at 23°C	Drop out voltage(Min) at 23°C	Power consumption at rated voltage
3	133	22.5	160 % of rated voltage	75 % of rated voltage	10 % of rated voltage	approx. 0.4W
5	80	62.5				
6	67	90				
9	44	202.5				
12	33	360				
15	27	563				
18	22	810				
21	19	1,103				
24	17	1,440				
36	11	3,240				
48	8.3	5,760				
60	6.7	9,000				
100	4.0	25,000				
110	3.6	30,250				

## »» Specification

Contact material	AgSnO / AgNi / AgCdO alloy	
Contact resistance <sup>(1)</sup>	50mΩ Max. (1A(100mA for Au-plating contact)/6VDC by 4 pipes mΩ meter)	
Operate time <sup>(1)</sup>	20ms Max.	
Release time <sup>(1)</sup>	10ms Max.	
Insulation resistance <sup>(1)</sup>	1000MΩ Min. (DC 500V)	
Dielectric strength <sup>(1)</sup>	Between open contact	: AC 1000V , 50/60Hz 1 min.
	Between contact and coil	: AC 5000V , 50/60Hz 1 min.
Vibration resistance	Operating extremes	10~55Hz , amplitude 1.5 mm
	Damage limits	10~55Hz , amplitude 1.5 mm
Shock resistance	Operating extremes	10G
	Damage limits	100G
Life expectancy	Mechanical	10,000,000 operations (frequency 18,000 operations/hr)
	Electrical	100,000 operations (frequency 1,800 operations/hr)
Operating ambient temperature	-40~+85°C (no freezing)	
Weight	Approx. 17 g	

Note : (1) initial value

## »» Safety Approval

Certified	UL / CUL	TUV
File No.	E88991	R 50025929

## »» Safety Approval Rating

UL / CUL		TUV
B、BA / C、CA	H、HA	
20A 277VAC	20A 277VAC	17A 250VAC
1 1/2HP 250VAC	1 1/2HP 250VAC	20A 250VAC
1HP 125VAC	8A 120VAC Tungsten	12A 250VAC cos φ 0.4

## »» Outline Dimensions

### ◆ 302P

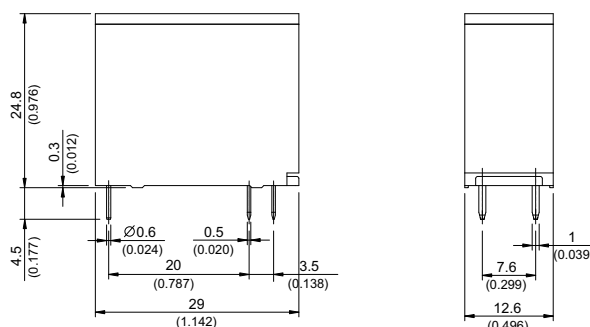

◆ 302WP

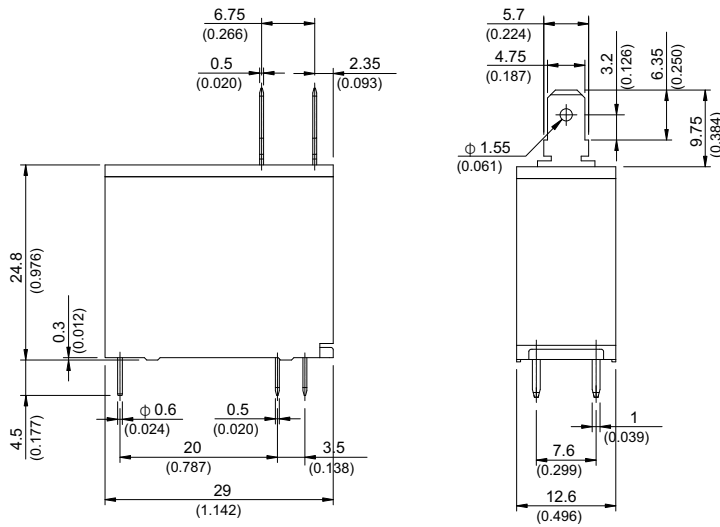

◆ 302WP1

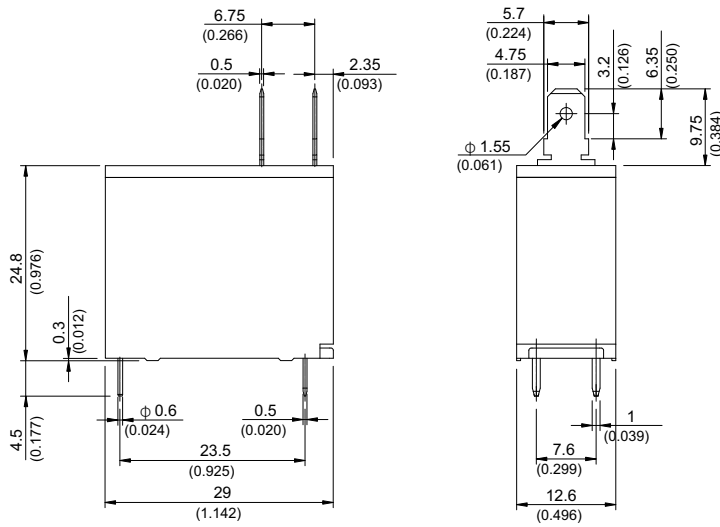

◆ 302WP2

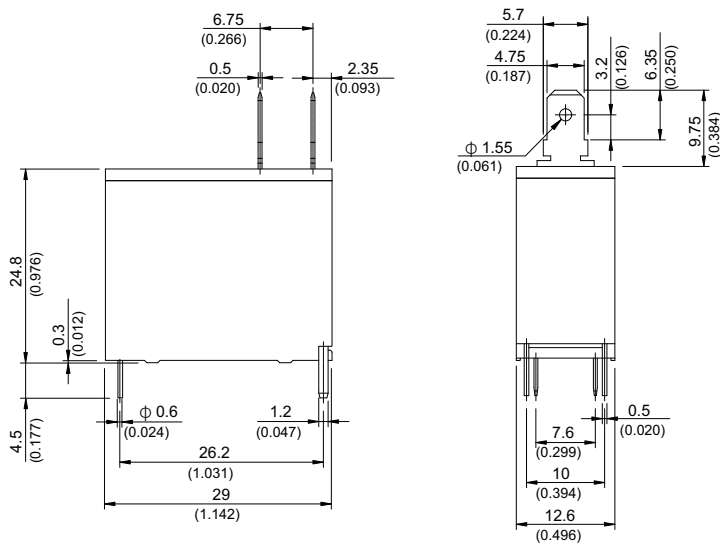

» Wiring Diagram  
BOTTOM VIEW



# 302

## »» PC Board Layout BOTTOM VIEW

### ◆302P, 302WP

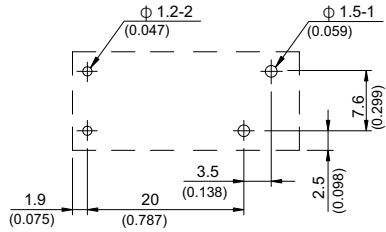

### ◆302WP1

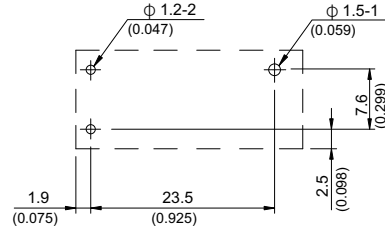

### ◆302WP2

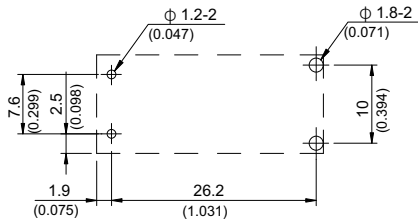

## »» Engineering Data

